

- Announcements
 - Exams back today
- Last Time
 - Motors/torque, magnetic moment
 - Faraday's Law
- Today
 - The infinite formula sheet
 - Circular motion of a charged particle
 - Motor review
 - Ampere's Law
 - Maxwell equations?

How do I avoid an infinite formula sheet?

The deeper the understanding, the fewer the formulae.

E&M has four equations total (Maxwell's equations)

Maxwell's Equations

$$\int \vec{E} \cdot d\vec{A} = \frac{Q}{\epsilon_0} \quad \text{To calculate E for symmetrical charges.}$$

$$\int \vec{B} \cdot d\vec{A} = 0 \quad \text{Cannot have North magnet w/o a South pole.}$$

$$\int \vec{B} \cdot d\vec{l} = \mu_0 I \quad \text{To calculate B for symmetrical currents.}$$

$$\int \vec{E} \cdot d\vec{l} = -\frac{d\Phi}{dt} \quad \text{Magnetic induction! Generators! Light!}$$

How do I avoid an infinite formula sheet?

The deeper the understanding, the fewer the formulae.

E&M has four equations total (Maxwell's equations)

... REALLY??

How do I avoid an infinite formula sheet?

The deeper the understanding, the fewer the formulae.

E&M has four equations total (Maxwell's equations)

... REALLY??

... no not yet

How do I avoid an infinite formula sheet – Physics I

$$KE_i + U_i = KE_f + U_f \quad \text{Energy conservation.}$$

$$F_c = \frac{mv^2}{R} \quad \text{Centripetal force in circular motion.}$$

$$F_{\text{net}} = m \vec{a} = \frac{d\vec{p}}{dt} \quad \text{Newton's 2nd}$$

$$W = \int \vec{F} \cdot d\vec{l} \quad \text{Definition of work.}$$

$$U = -W \quad \text{Relation between work and Potential Energy}$$

$$\vec{\tau} = \vec{r} \times \vec{F} = I\alpha \quad \text{Torque definition}$$

How do I avoid an infinite formula sheet – really?

$$\Delta V = - \int \vec{E} \cdot d\vec{l} \quad \text{Definition of potential.}$$

$$\oint \vec{E} \cdot d\vec{A} = \frac{Q}{\epsilon_0} \quad \text{Gauss Law (sphere/line/plane).}$$

$$Q = CV \quad \text{Def. of capacitance}$$

$$V = IR \quad R = \rho \frac{L}{A} \quad \text{Ohm's Law and origin of resistance}$$

$$U = qV \quad \text{Relation between potential and potential energy}$$

$$\vec{F} = q\vec{E} + q\vec{v} \times \vec{B} \quad \text{Lorentz force Law}$$

$$\oint \vec{B} \cdot d\vec{l} = \mu_0 I \quad \text{Ampere's law (wire/solenoid/current sheet).}$$

How do I avoid an infinite formula sheet – Example ... Circular motion in a B-field

Given a proton moving at 1000 km/s in Earth's magnetic field, what is the radius and frequency of the orbit?

Motor Review

Motors

Are just clever loops of wire in magnetic fields

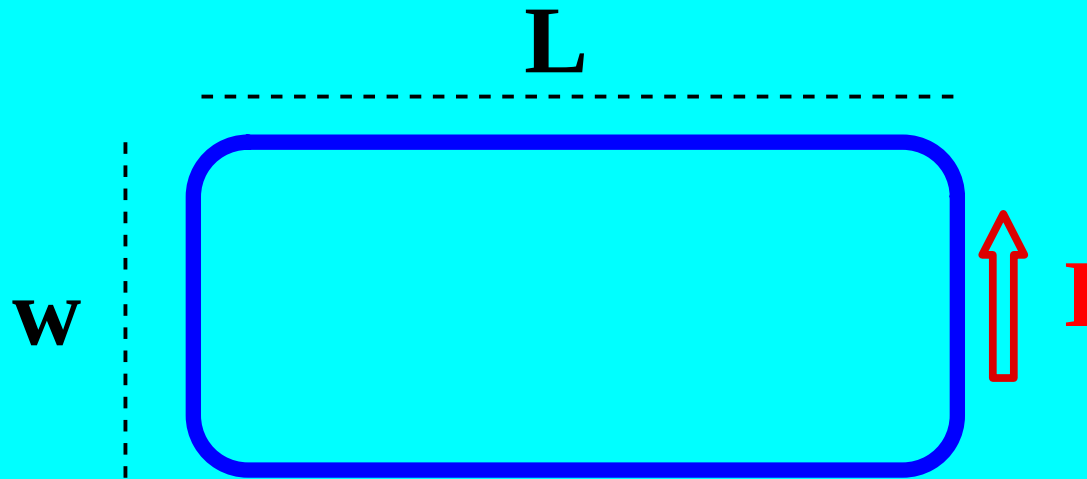

$$\vec{F} = I \vec{L} \times \vec{B} \quad \text{Force on current } I$$



Try B-field to the right

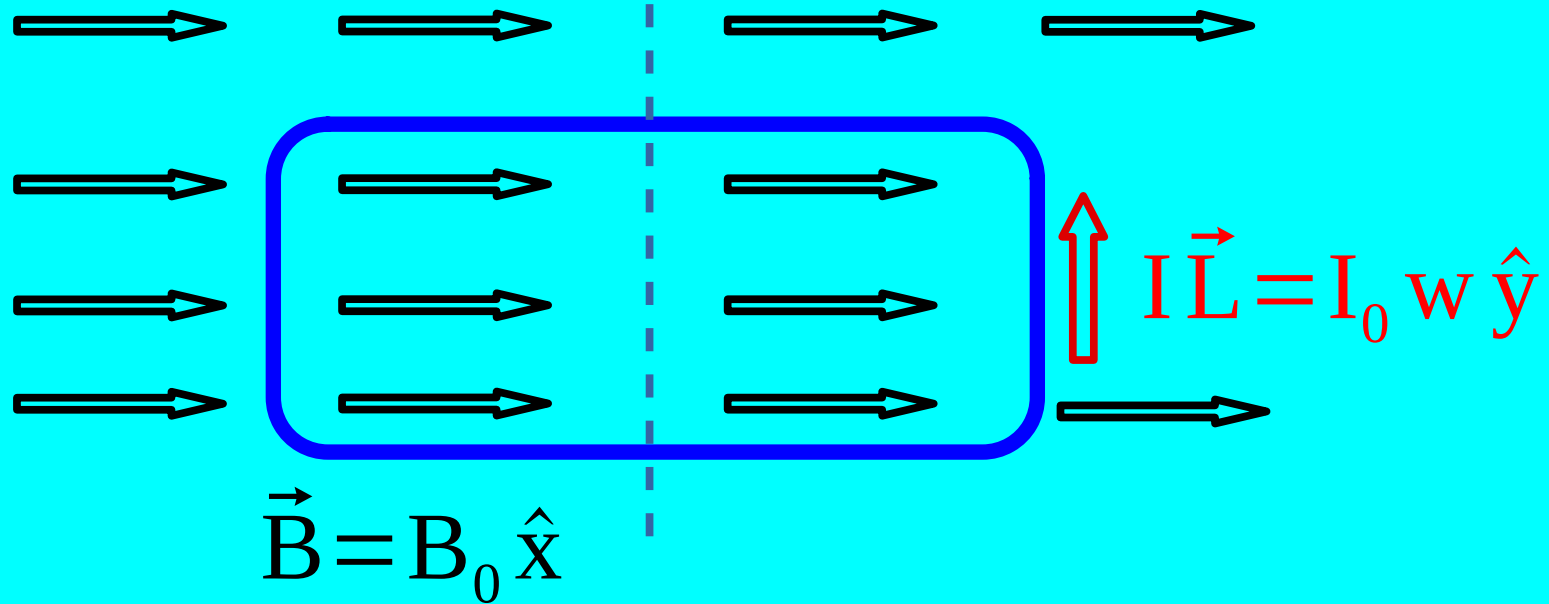

$$\vec{F} = I\vec{L} \times \vec{B} \quad \text{Force on current } I$$

Equations for motors

$$\vec{F} = I \vec{L} \times \vec{B} \quad \text{Force on current } I$$

$$\vec{\tau} = \vec{r} \times \vec{F} \quad \text{Torque definition}$$

$$\vec{m} = N I \vec{A} \quad \text{Def. of Magnetic Moment}$$

$$\vec{\tau} = \vec{m} \times \vec{B} \quad \text{Torque on a Magnetic Moment}$$

This is a side view of a wire loop. Which direction should \mathbf{B} point for maximum torque?

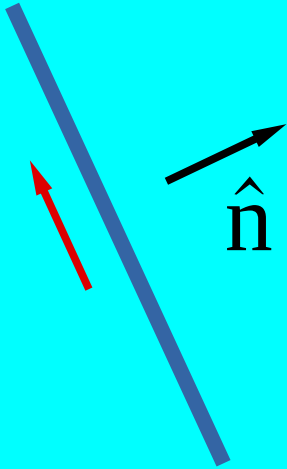

- (A) To the right
- (B) Up
- (C) Along \hat{n}
- (D) Perpendicular to \hat{n}

This is a side view of a wire loop. Which direction should \mathbf{B} point for zero torque?

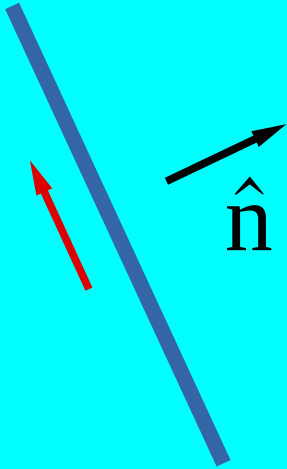

- (A) To the right
- (B) Up
- (C) Along \hat{n}
- (D) Perpendicular to \hat{n}

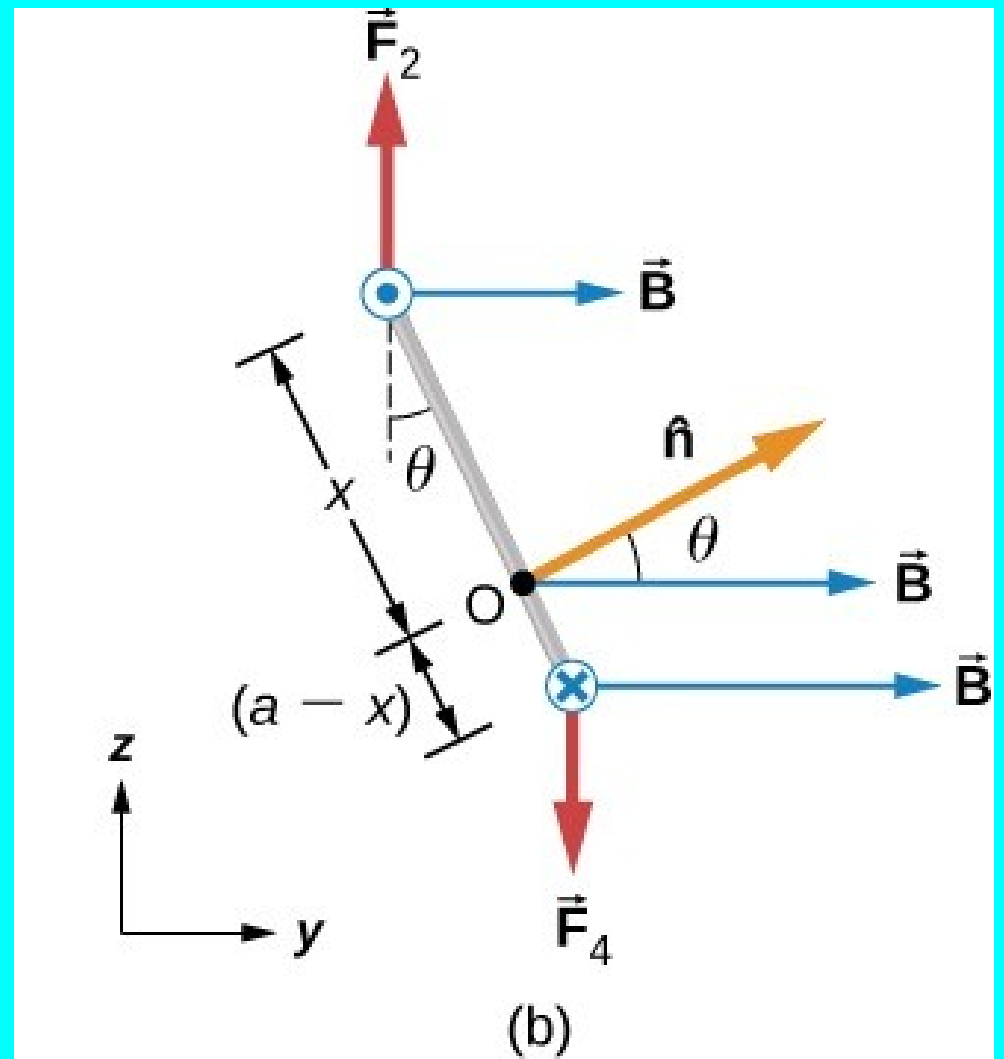

In a 2 T B-field, what is the maximum torque on this loop?

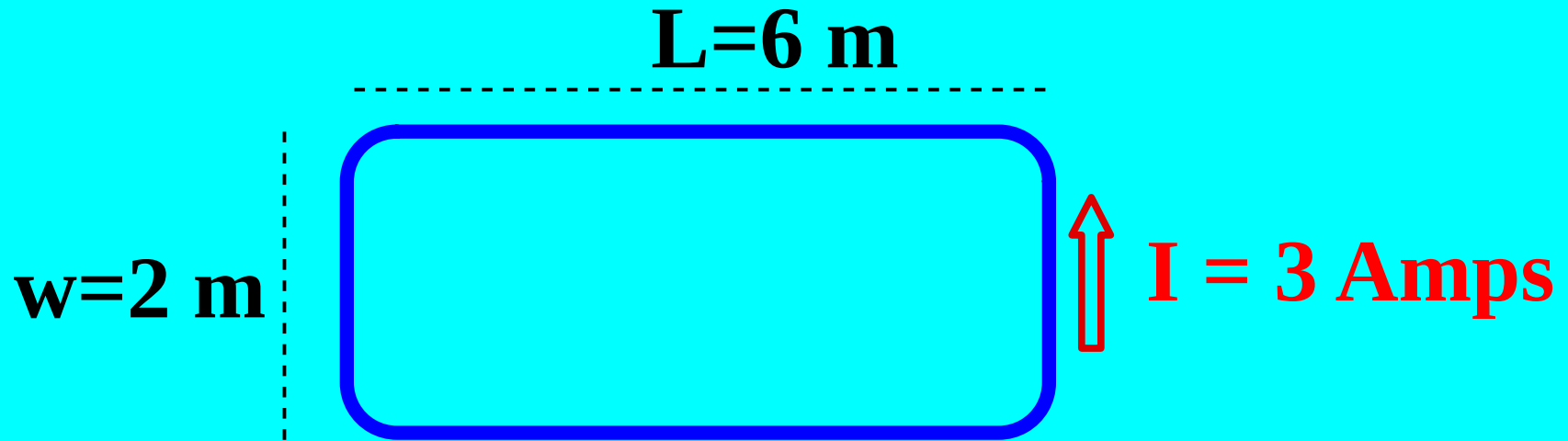

- (A) $\tau = 6 \text{ N}\cdot\text{meter}$
- (B) $\tau = 3 \text{ N}\cdot\text{meter}$
- (C) $\tau = 36 \text{ N}\cdot\text{m}$
- (D) $\tau = 72 \text{ N}\cdot\text{m}$

Ampere's Law

Is always true and is one of the Maxwell Equations

Allows you to calculate the magnetic field in highly symmetric cases of currents

$\int f(x) dx$ Area under y-axis

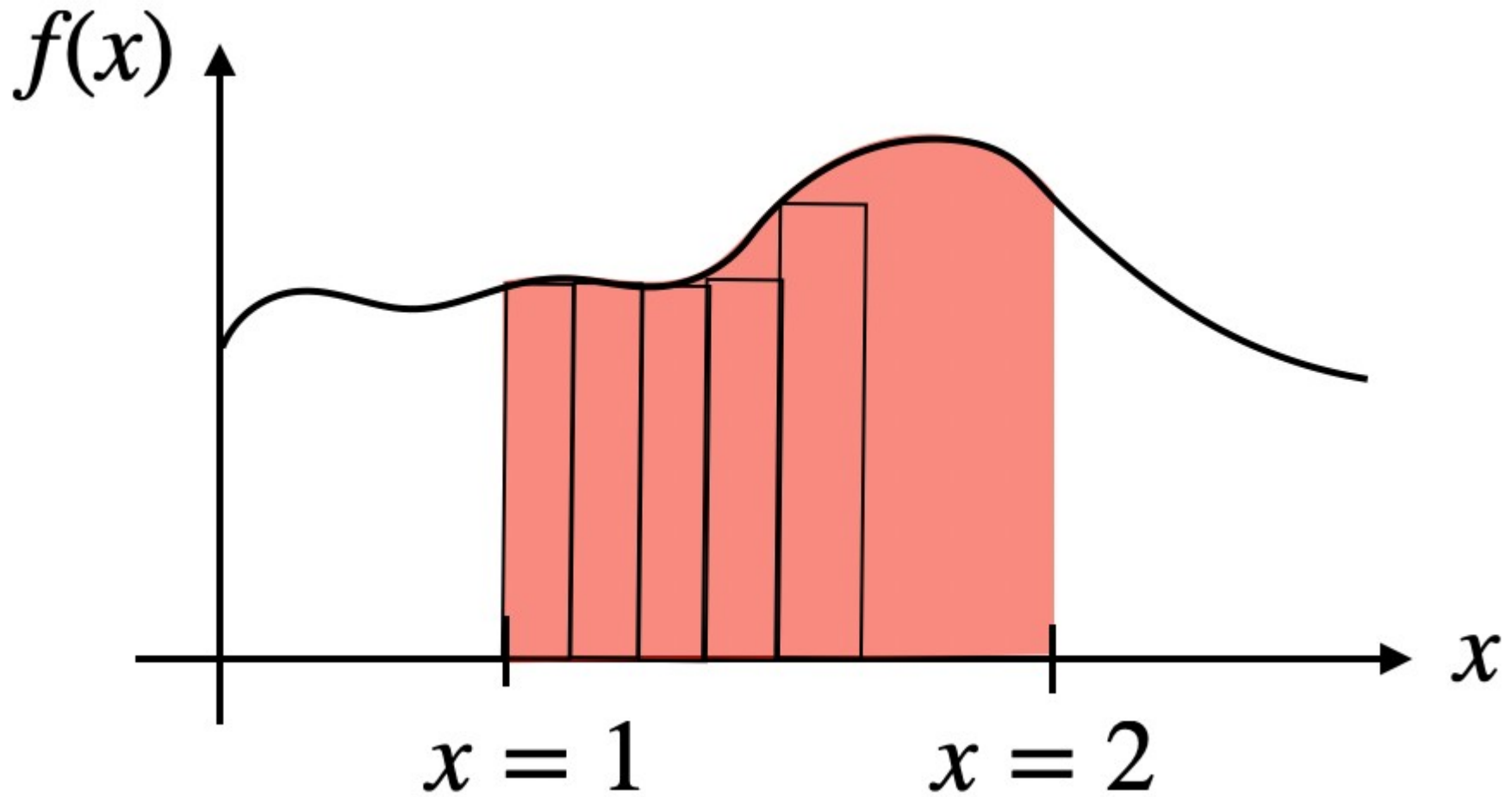

$\int f(x)dx$ Area under arbitrary line

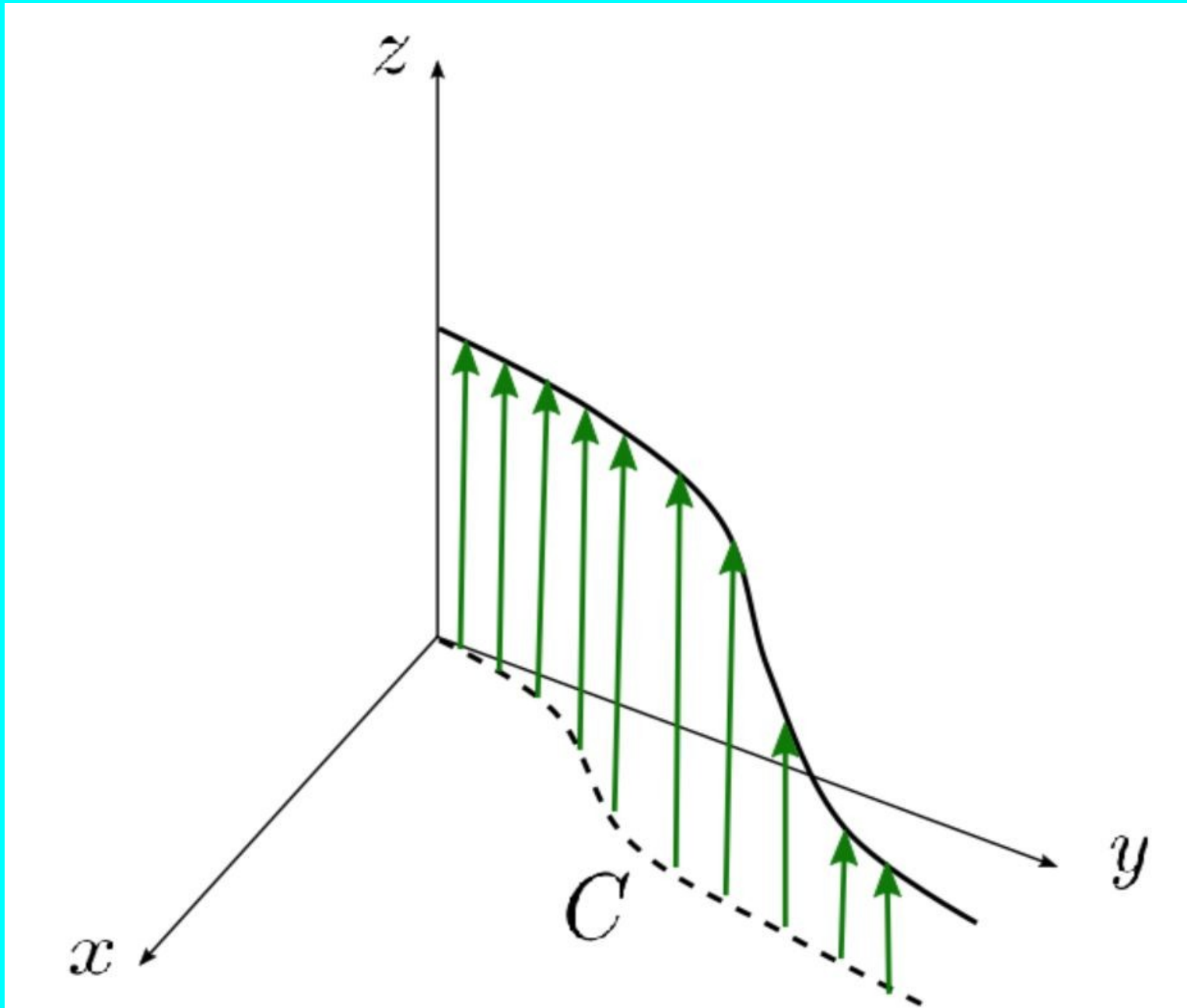

$\int \vec{F} \cdot d\vec{l}$ Vector line integral

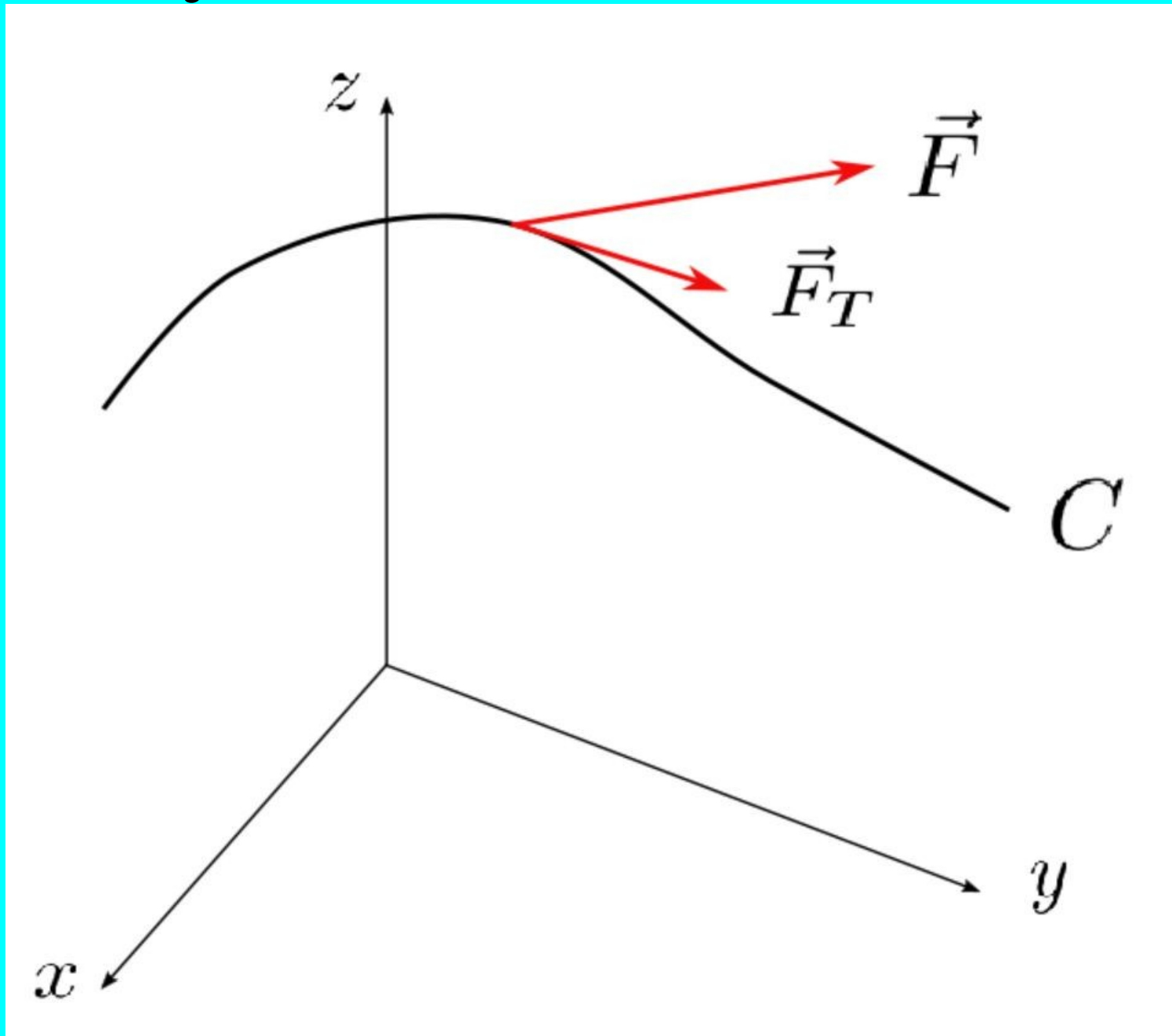

$\int \vec{F} \cdot d\vec{r}$ Vector line integral

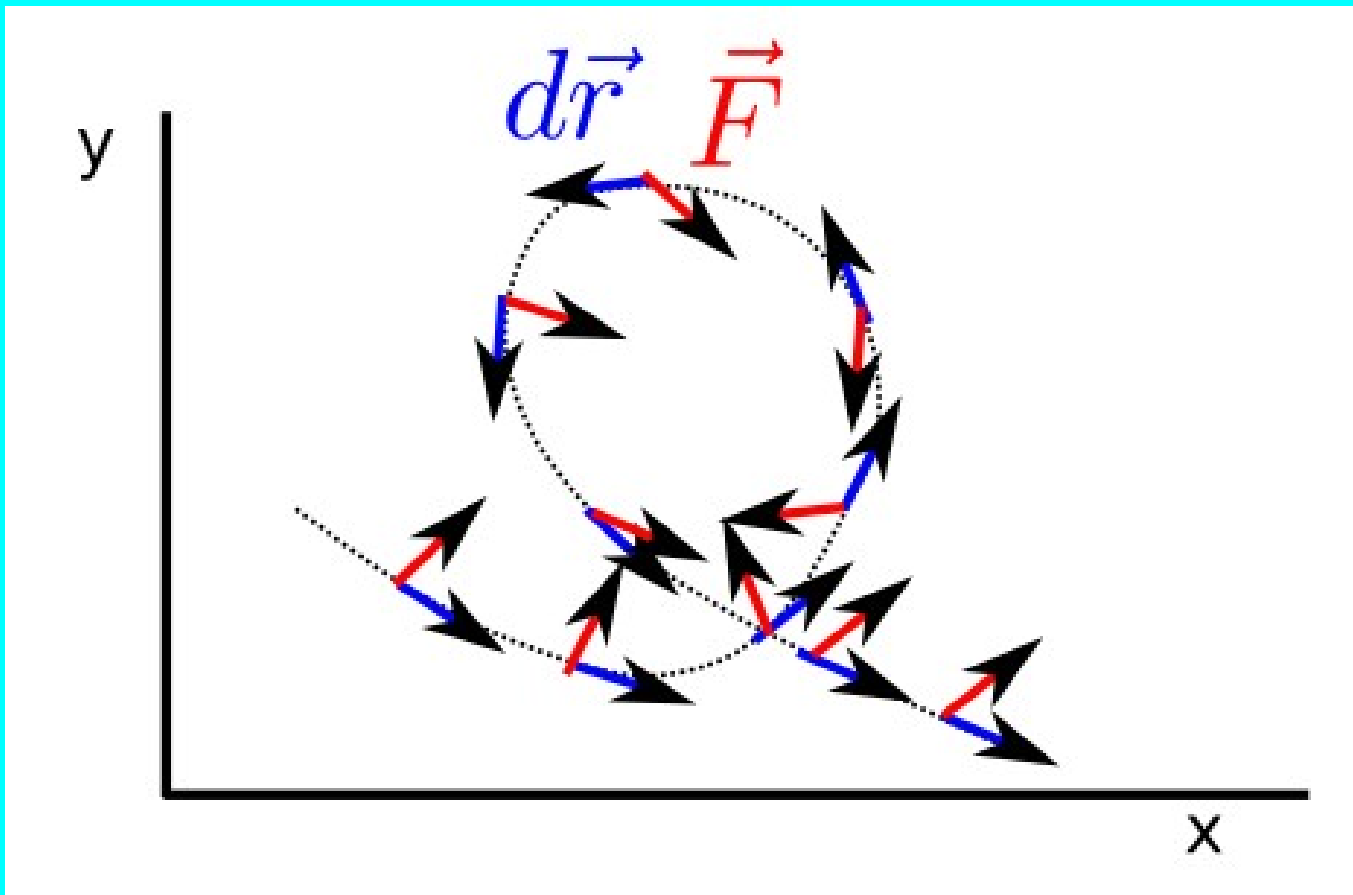

Clicker

- Where have you seen a vector line integral before?
 - (A) Plan 9 from outer space
 - (B) Friday the 13th part 4
 - (C) The definition of work
 - (D) The definition of electric potential
 - (E) Two of the above

$\oint \vec{F} \cdot d\vec{s}$ Vector closed-loop line integral

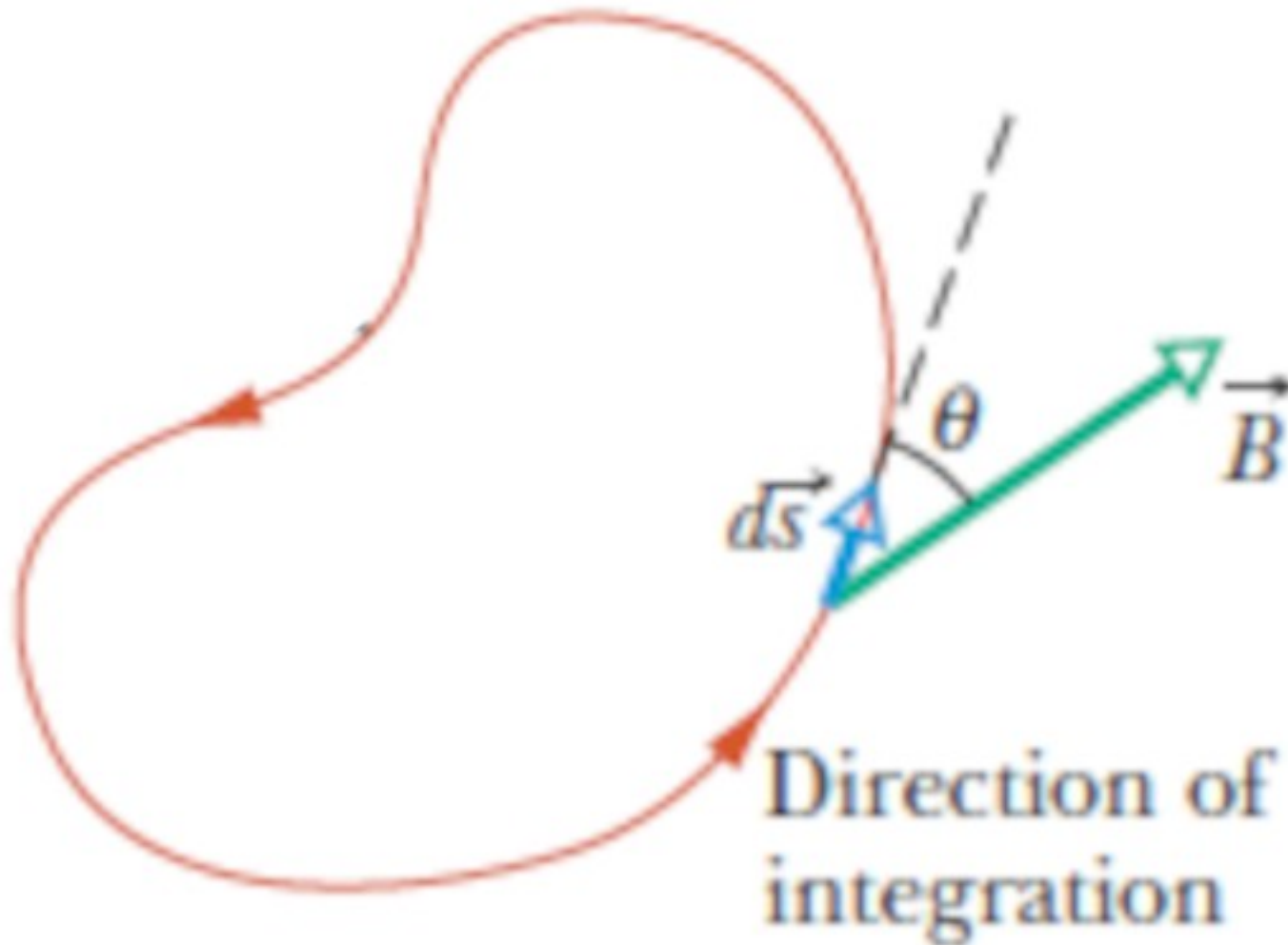

$\oint \vec{F} \cdot d\vec{r}$ Vector closed-loop line integral

$\oint \vec{B} \cdot d\vec{s} = \mu_0 I$ Ampere's Law

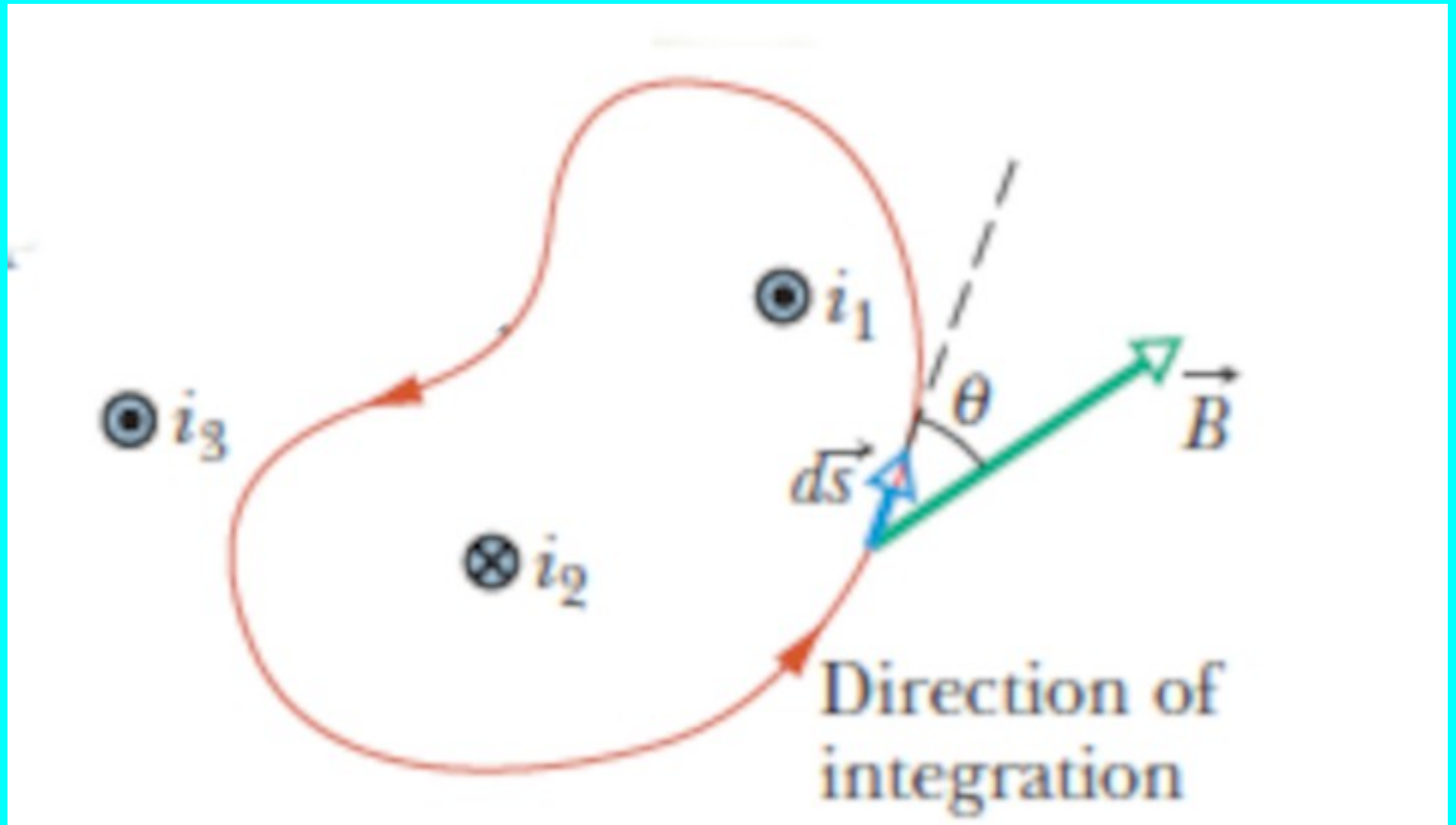

$$\oint \vec{B} \cdot d\vec{l} = \mu_0 I \quad \text{Ampere's Law}$$

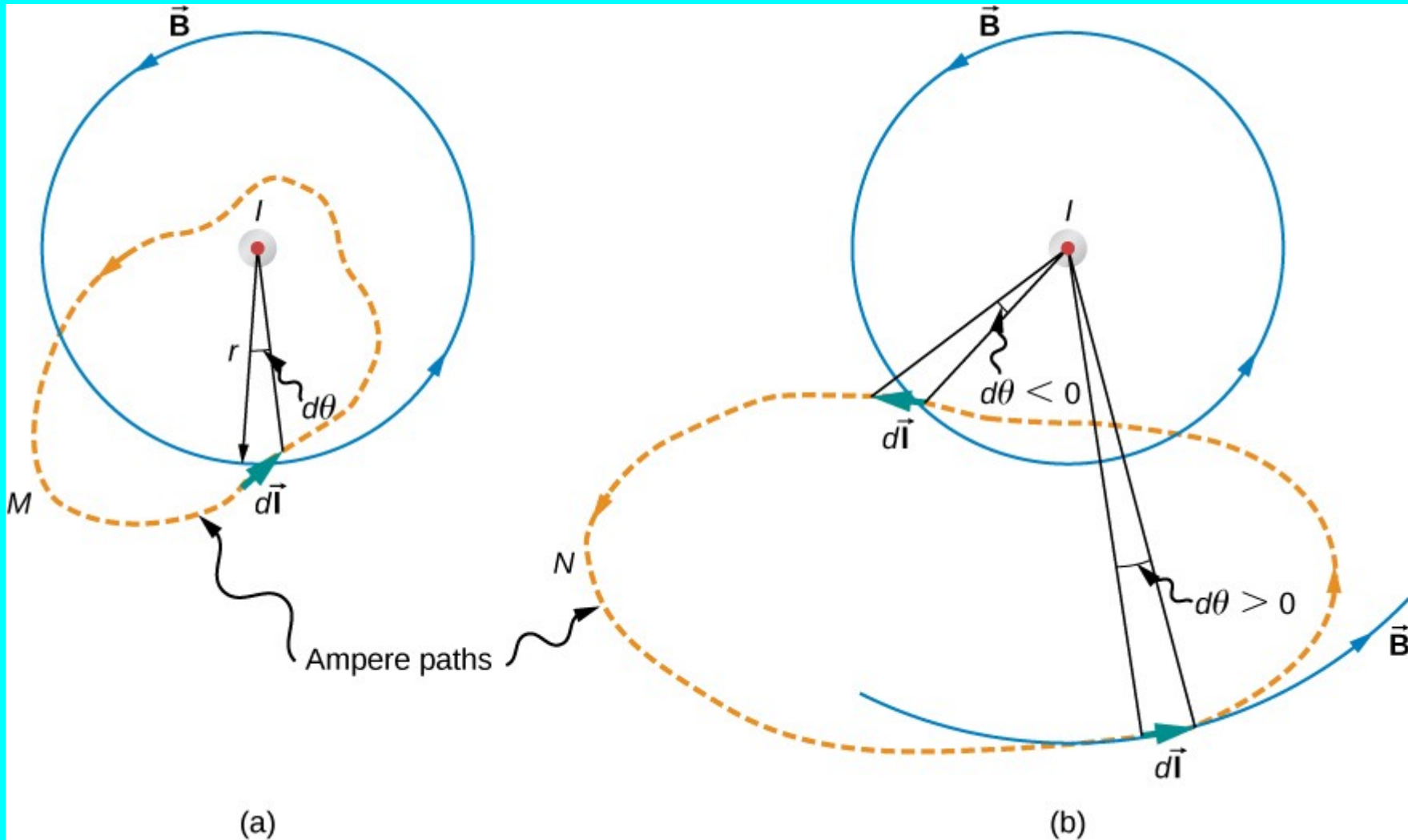

Given $i_1 = 10$ Amps, $i_2 = -5$ A, $i_3 = 5$ A

What is $\int \vec{B} \cdot d\vec{l}$?

(A) Plan 9 from outer space

(B) $10 \text{ T}\cdot\text{m}$

(C) $15 \text{ T}\cdot\text{m}$

(D) $5 \text{ T}\cdot\text{m}$

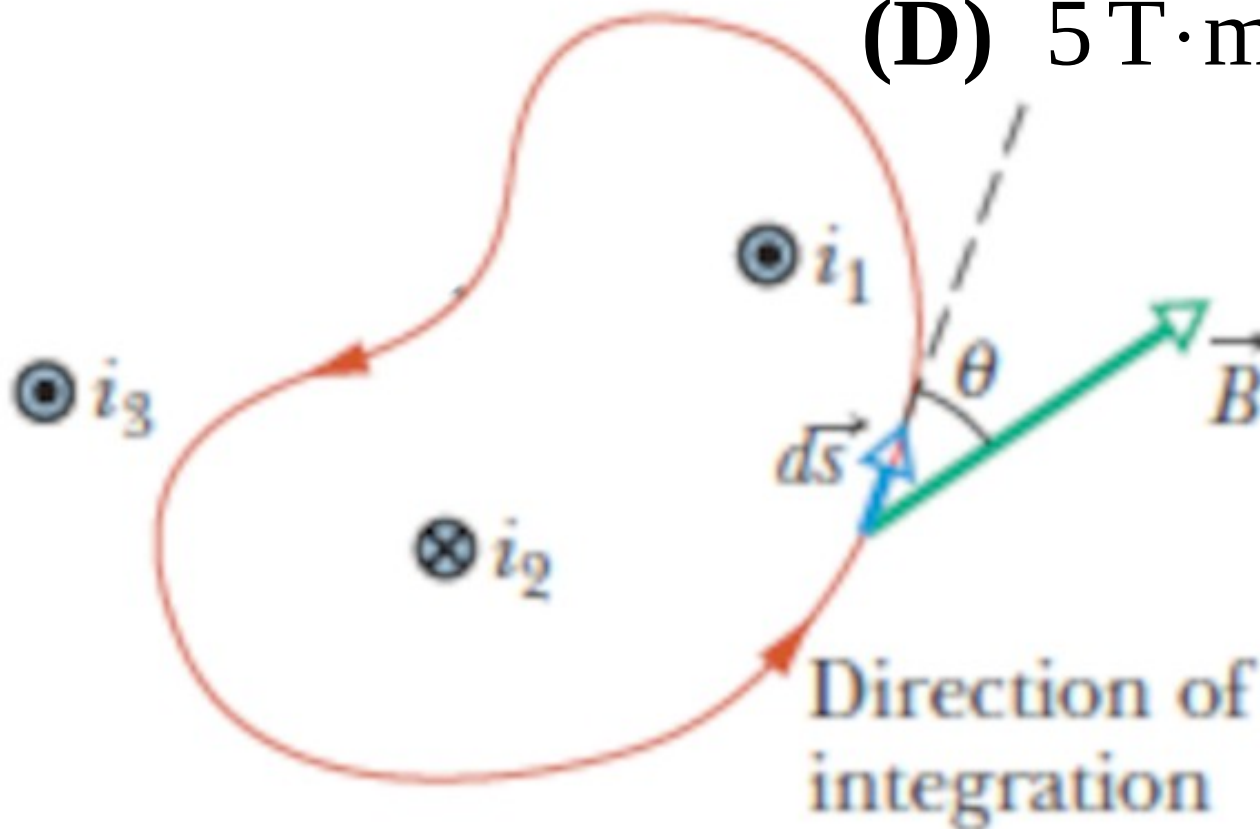

Equations of Magnetism

$$\vec{F} = Q \vec{v} \times \vec{B} \quad \text{Force on charge } Q$$

$$\vec{F} = I \vec{L} \times \vec{B} \quad \text{Force on current } I$$

$$\vec{B} = \frac{\mu_0 I}{2\pi r} \hat{\phi} \quad \text{Field of Infinite wire}$$

$$\vec{B} = \frac{\mu_0 I}{2a} \hat{z} \quad \text{Field in center of wire loop}$$

$$\vec{B} = \mu_0 n I \hat{z} \quad \text{Field of an infinite coil (solenoid)}$$

Derive field around a wire

Derive field of a solenoid

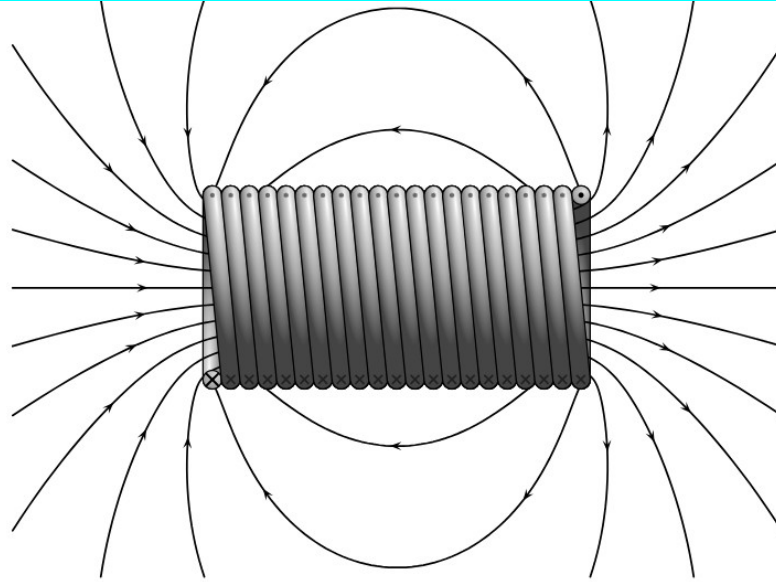

$$\vec{E} = \frac{\sigma}{2\epsilon_0} \hat{k}$$

Planar symmetry

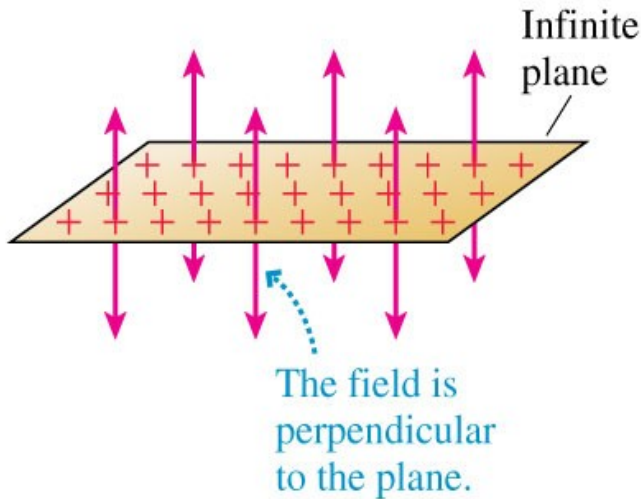

Infinite parallel-plate capacitor

$$\vec{E} = \frac{\lambda}{2\pi r \epsilon_0} \hat{r}$$

Cylindrical symmetry

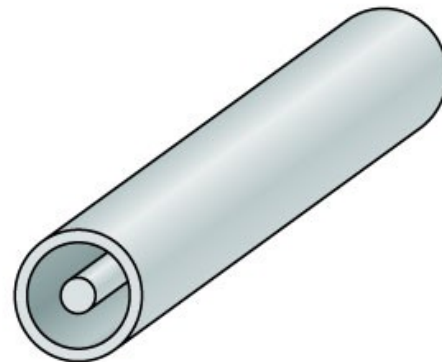
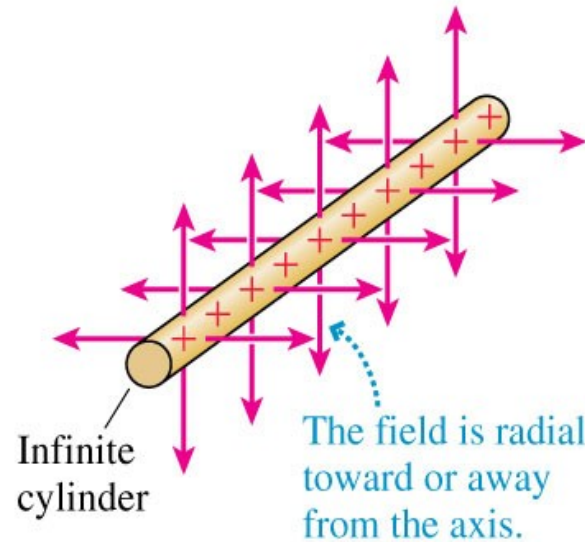

Coaxial cylinders

$$\vec{E} = \frac{Q}{4\pi r^2 \epsilon_0} \hat{r}$$

Spherical symmetry

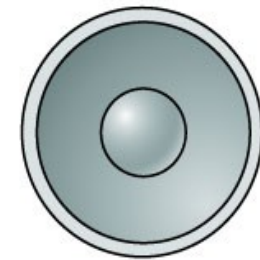
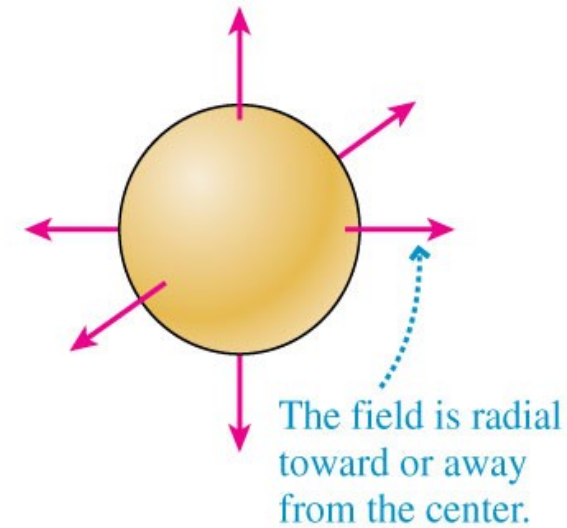

Concentric spheres

Maxwell's Equations

$$\int \vec{E} \cdot d\vec{A} = \frac{Q}{\epsilon_0} \quad \text{To calculate E for symmetrical charges.}$$

$$\int \vec{B} \cdot d\vec{A} = 0 \quad \text{Cannot have North magnet w/o a South pole.}$$

$$\int \vec{B} \cdot d\vec{l} = \mu_0 I \quad \text{To calculate B for symmetrical currents.}$$

$$\int \vec{E} \cdot d\vec{l} = -\frac{d\Phi}{dt} \quad \text{Magnetic induction! Generators! Light!}$$

Faraday's Law

A changing magnetic flux makes a voltage.
Moving a magnet in a loop of wire makes a voltage.

Spinning a wire in a magnetic field makes a Voltage

Turning on an electromagnet near a coil of wire makes a voltage.

Faraday's Law Lab

You will yank a loop of wire out of a magnetic field. This will allow you to measure the magnetic field.

You will run an AC current through a coil. This will cause a voltage to appear in a different coil.

**Electric fields are calculated with
Coulomb's law or Gauss's Law**

**Magnetic Fields are calculated with the
Biot-Savart Law or Ampere's Law**

$$d\vec{B} = \frac{\mu_0}{4\pi} \frac{I d\vec{l} \times \hat{r}}{r^2} \quad \text{Biot Savart}$$

Maxwell's Equations

$$\oint \vec{E} \cdot d\vec{A} = \frac{Q}{\epsilon_0} \quad \text{To calculate E for symmetrical charges.}$$

$$\oint \vec{B} \cdot d\vec{A} = 0 \quad \text{Cannot have North magnet w/o a South pole.}$$

$$\oint \vec{B} \cdot d\vec{l} = \mu_0 I \quad \text{To calculate B for symmetrical currents.}$$

$$\oint \vec{E} \cdot d\vec{l} = -\frac{d\Phi_B}{dt} \quad \text{Magnetic induction! Generators! Light!}$$

$$\Phi_B = \int \vec{B} \cdot d\vec{A}$$

Recap Lecture 23

- Circular motion of charges
- Torque in a motor
- Amperes law
- Field of a wire
- Field of a solenoid
-

$\int f(x) dx$ Area under curve

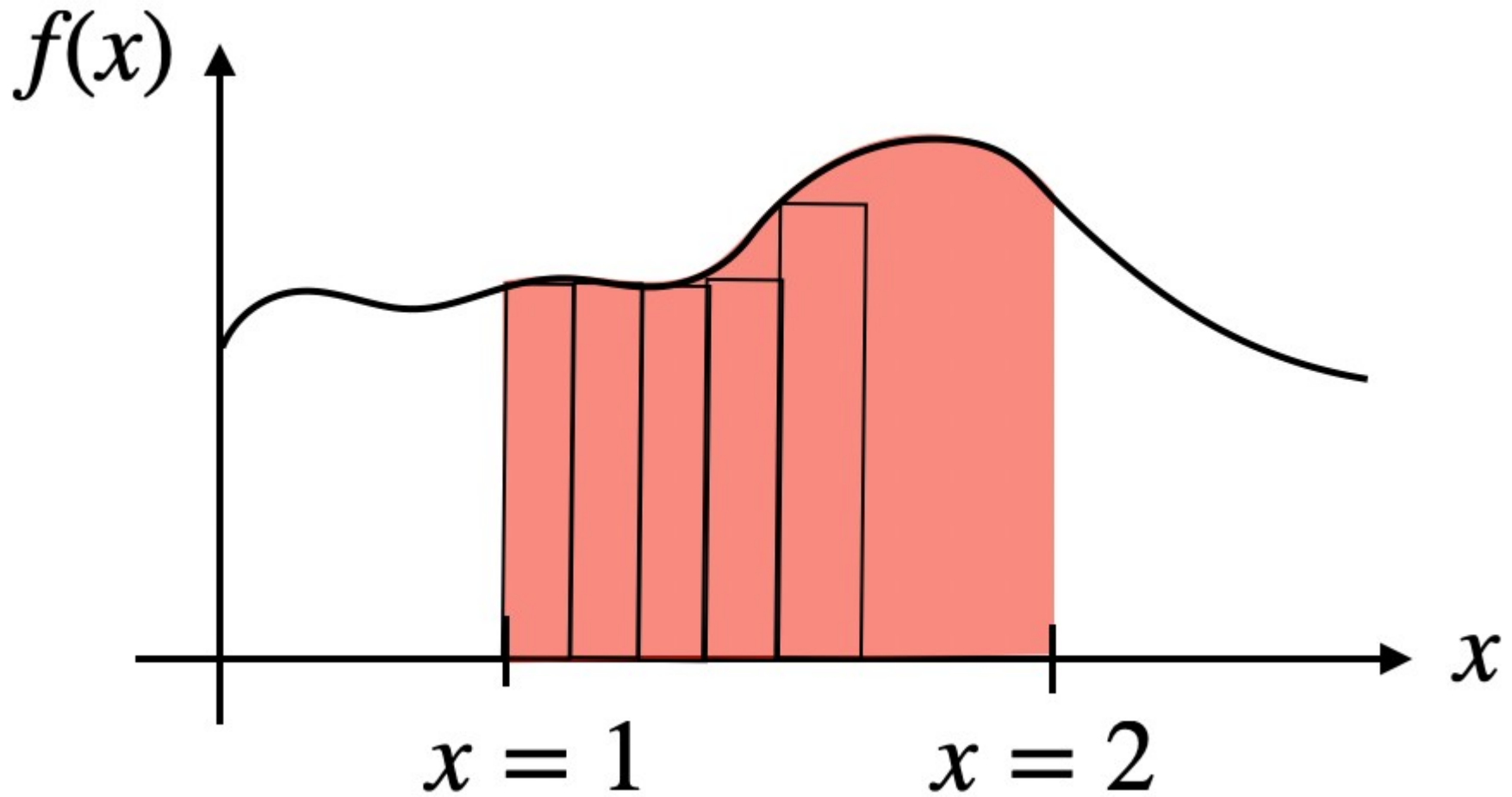

$$\int f(x, y) dA = \iint f(x, y) dx dy \quad \text{Volume under an area}$$

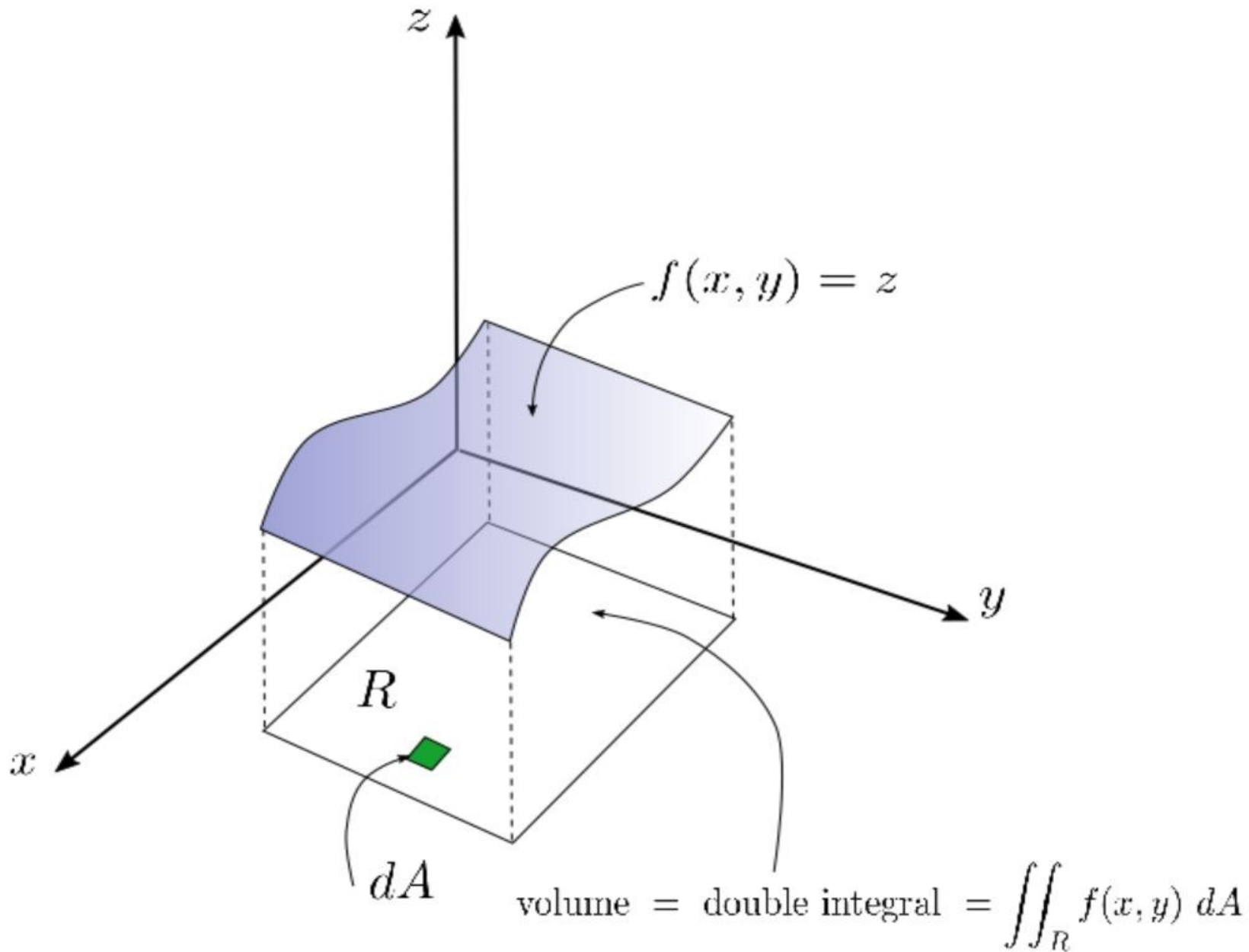

$$\int f(u, v) dA = \iint f(u, v) |\vec{r}_u \times \vec{r}_v| du dv \quad \text{Surface integral}$$

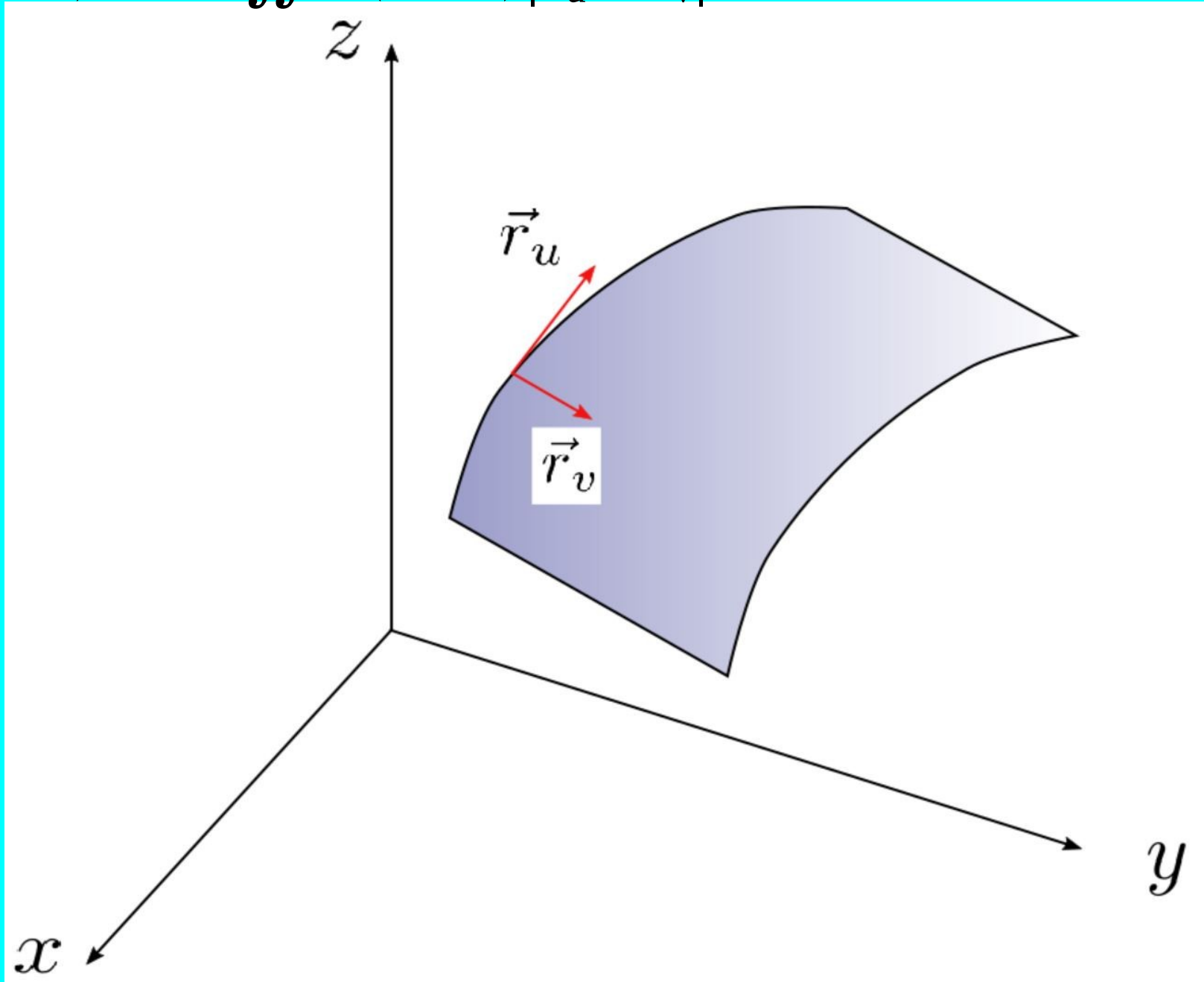

$\int \vec{F}(u, v) \cdot \hat{n} \, dA$ Vector surface integral

$$\iint \vec{F} \cdot (\vec{r}_u \times \vec{r}_v) \, du \, dv$$

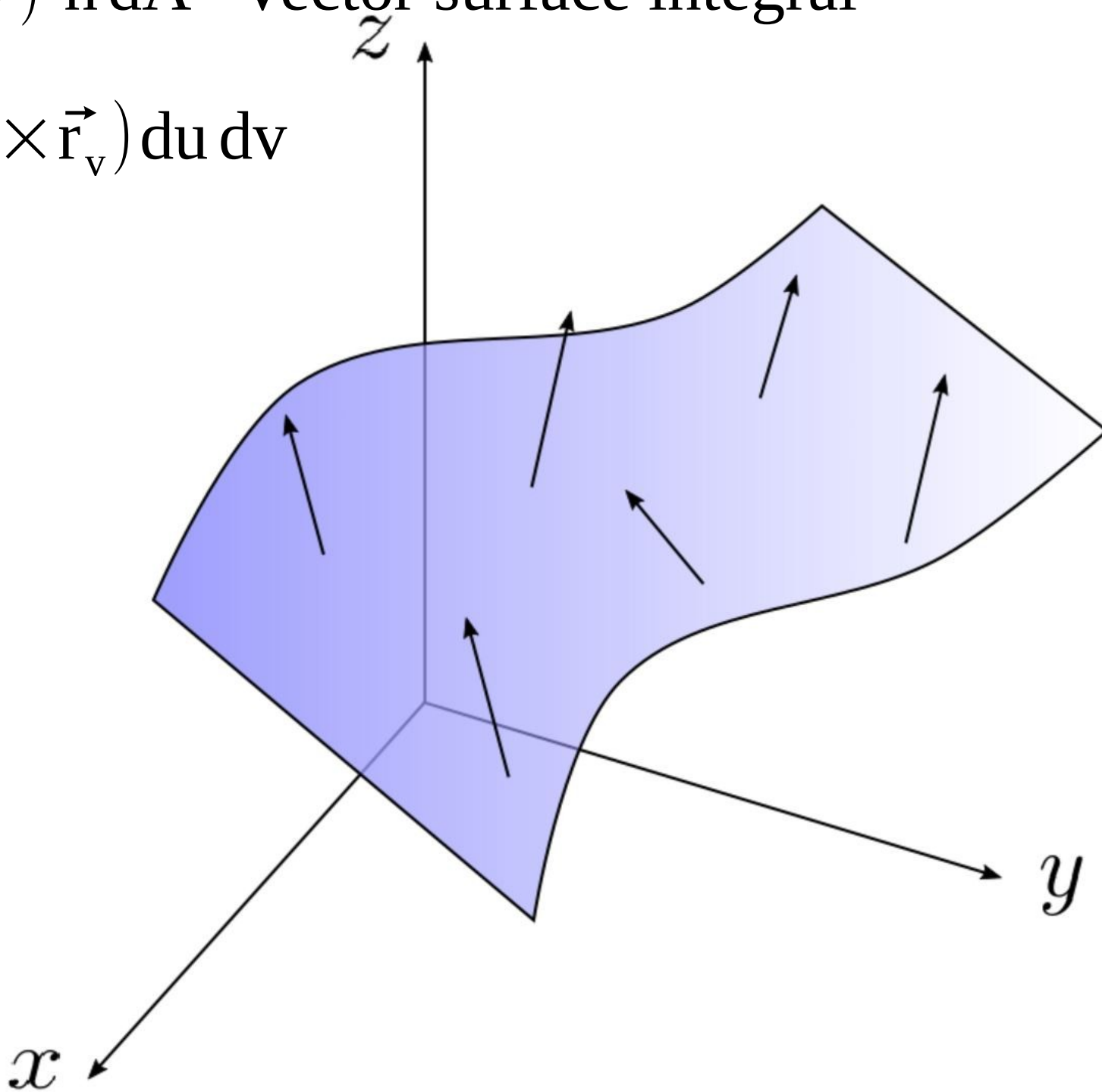

$\oint \vec{F}(u, v) \cdot \hat{n} \, dA$ Vector closed surface integral

$$\oint \vec{E} \cdot d\vec{A} = \frac{Q}{\epsilon_0}$$

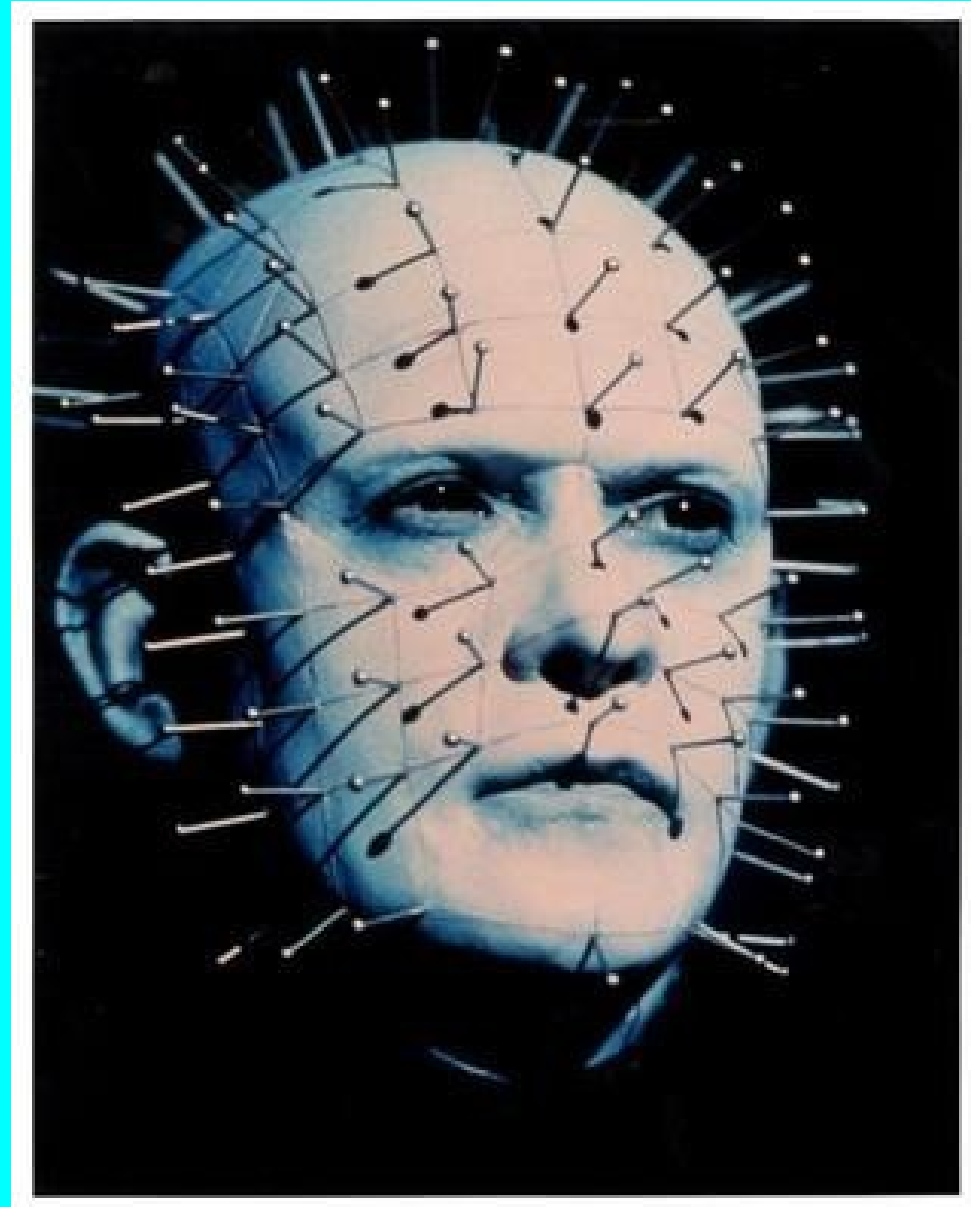

$\int f(x) dx$ Area under y-axis

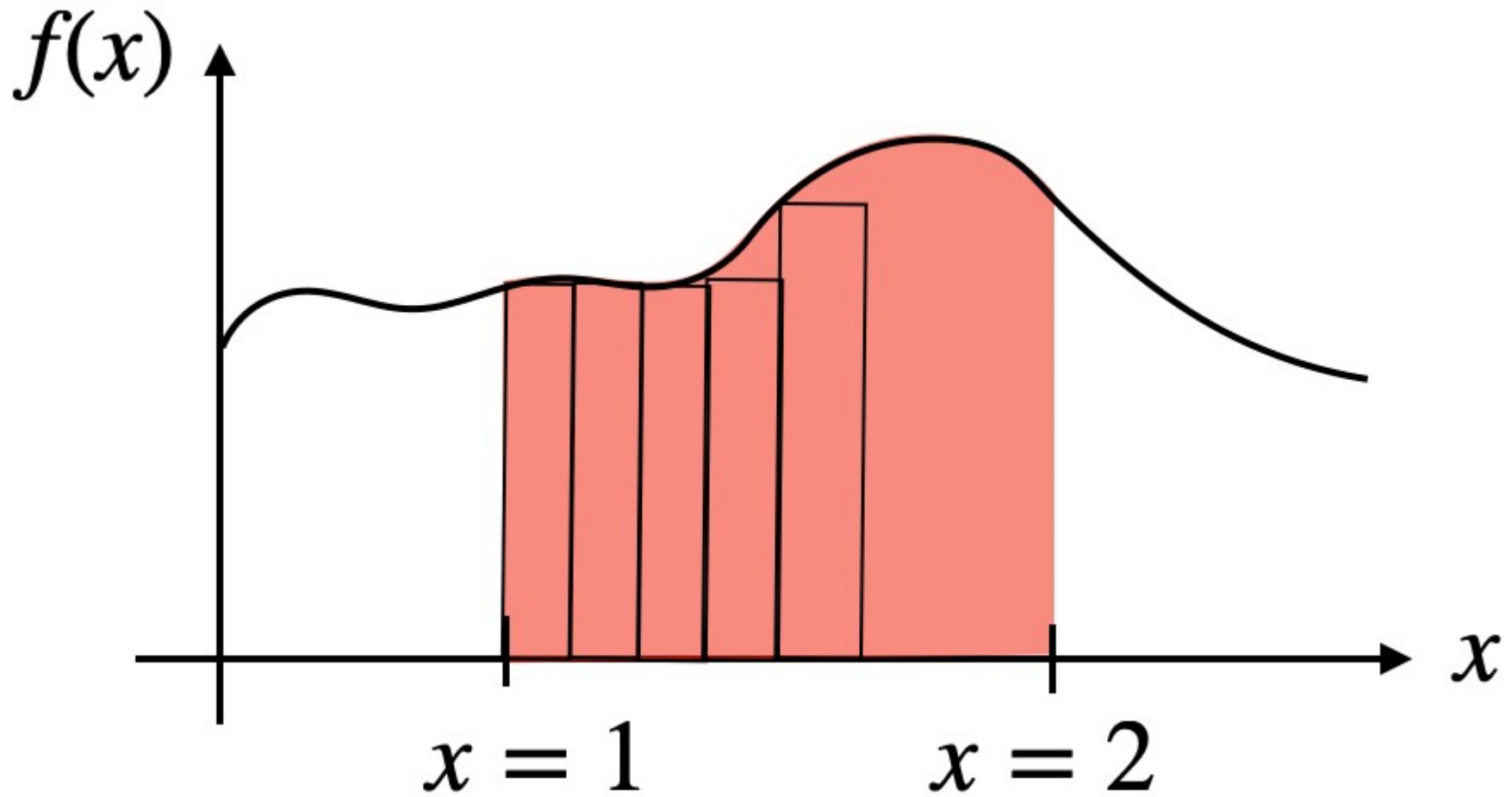

$\int f(x)dx$ Area under arbitrary line

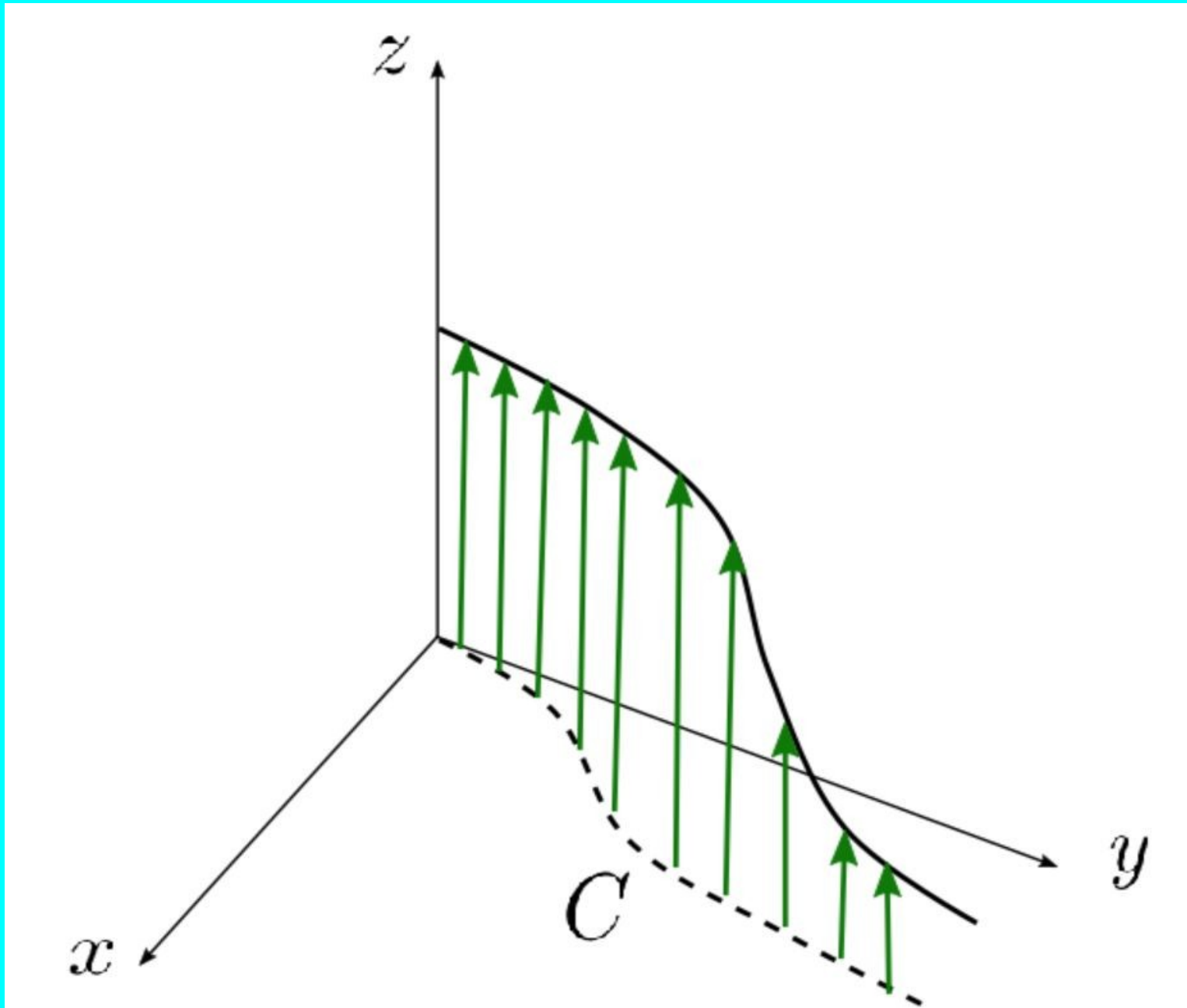

$\int \vec{F} \cdot d\vec{l}$ Vector line integral

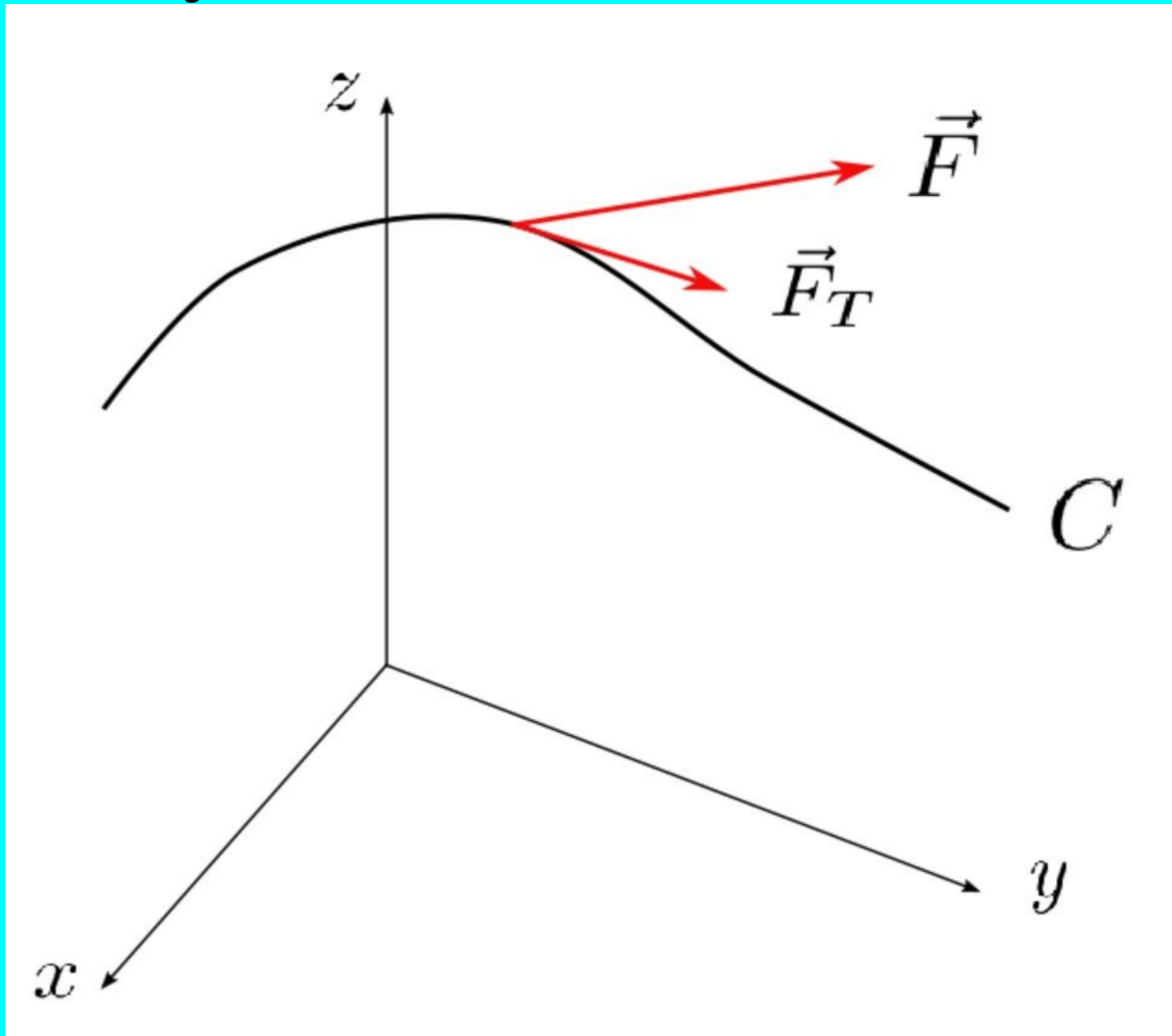

$\int \vec{F} \cdot d\vec{r}$ Vector line integral

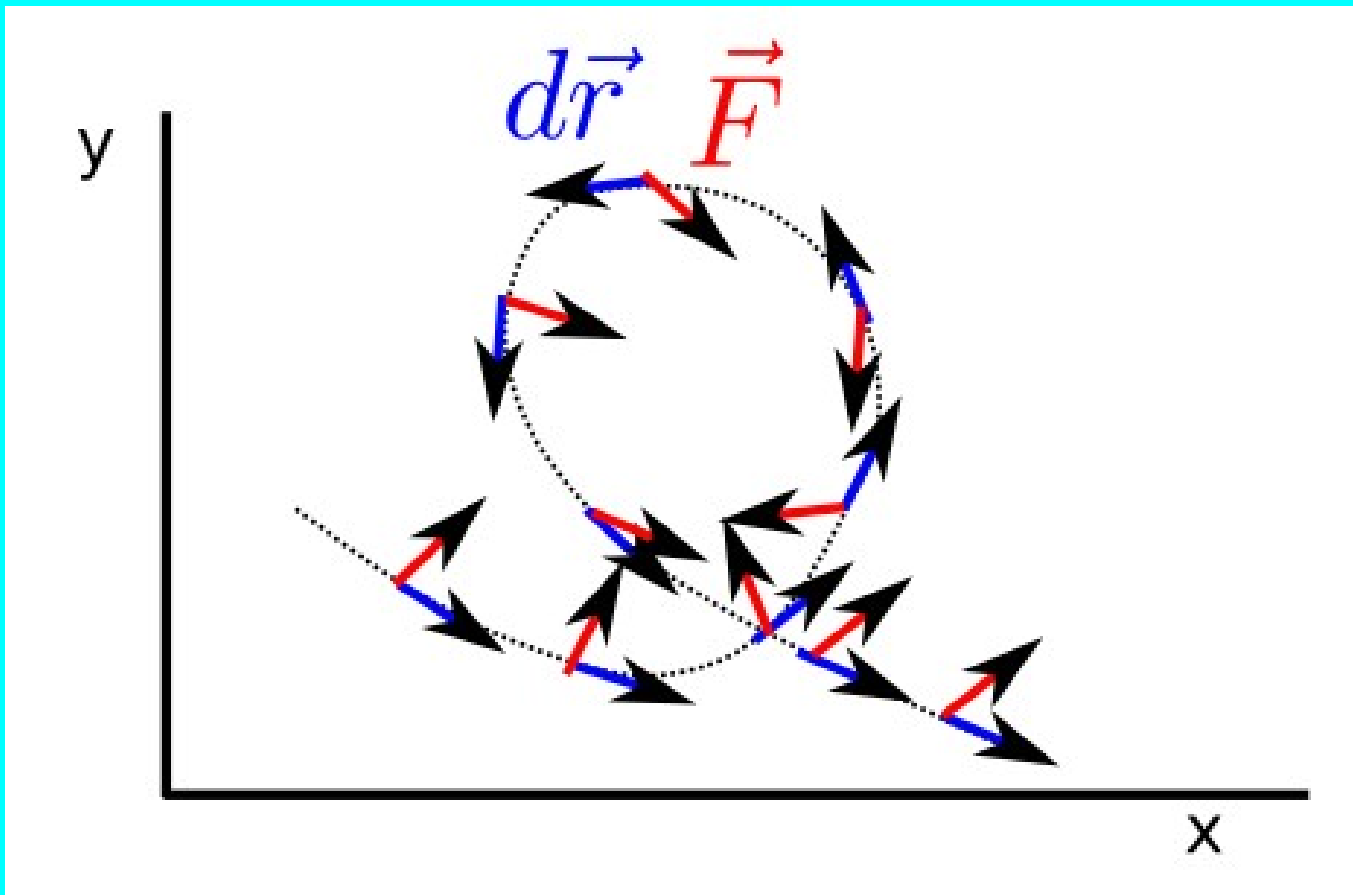

$\oint \vec{B} \cdot d\vec{s}$ Vector closed-loop line integral

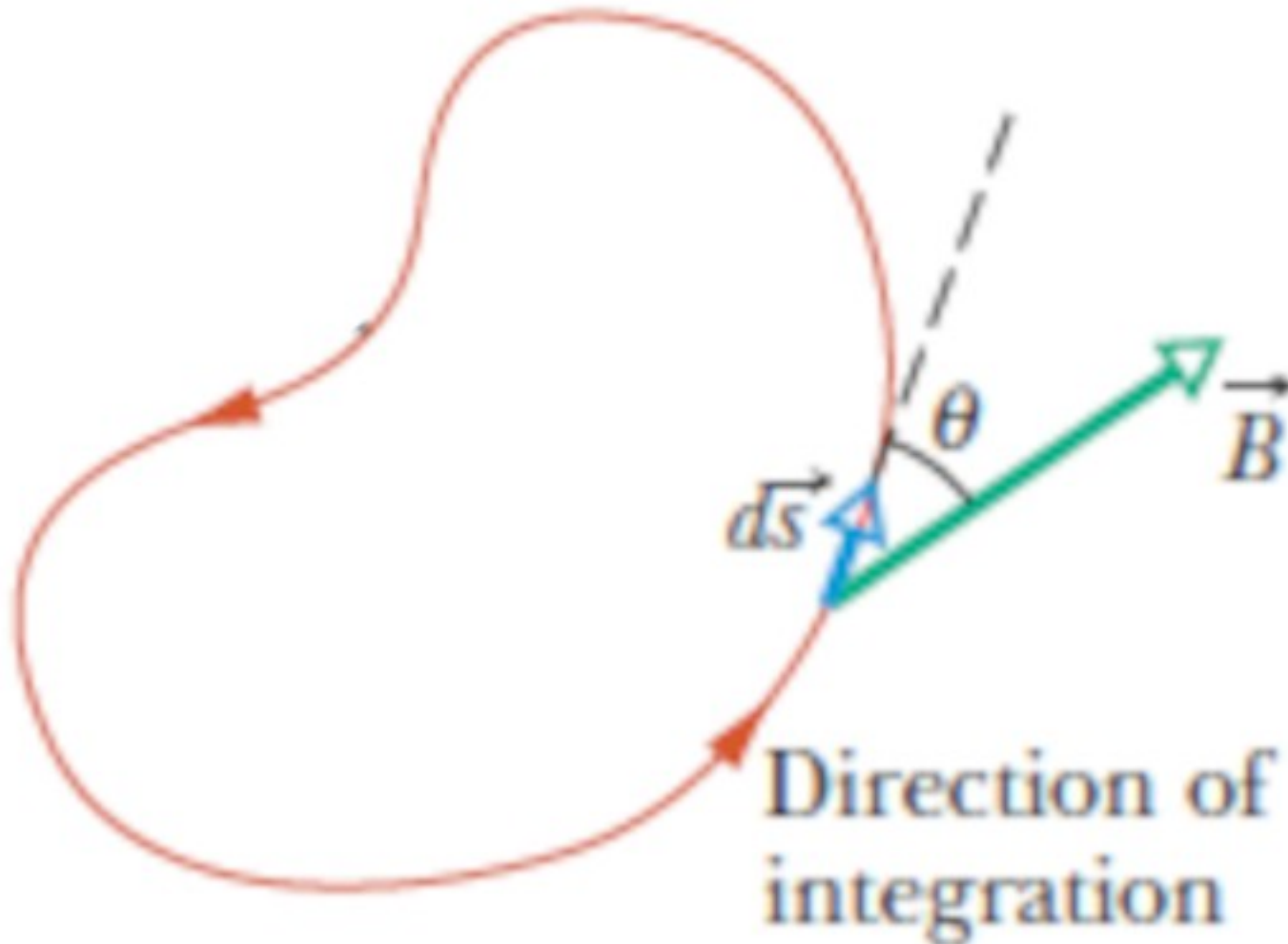

Torque

- A wrench is 30 cm long and a person exerts 10 N at right angles to it. The torque is?
 - (A) 30 N·m
 - (B) 10 N·m
 - (C) 300 N·m
 - (D) 3 N·m
 - (E) 0 N·m